

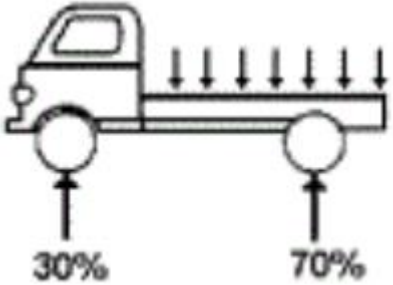

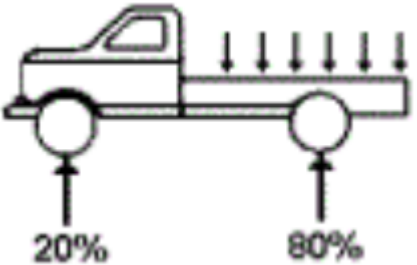

Directrices sobre carga de vehículos de transporte

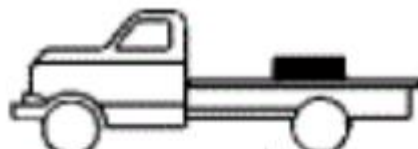

Distribución del peso por tipo de carrocería

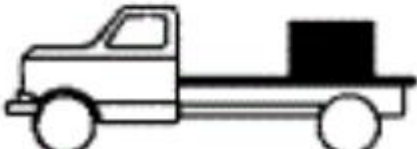
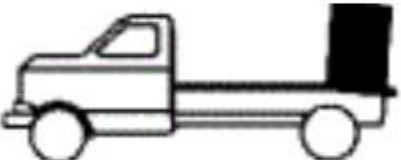
Camión con cabina sobre motor	Camión convencional
	

Procedimientos de carga para camiones convencionales y con cabina sobre motor



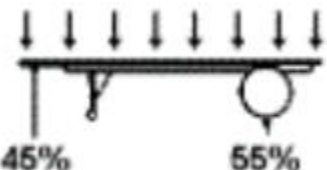

Carga correcta	Carga incorrecta
	
	
	

Distribución del peso por tipo de carrocería

Remolque y camión tractor		
		

Directrices sobre carga de vehículos de transporte



Procedimientos de carga de camiones tractores

Carga correcta	Carga incorrecta
	
	
	

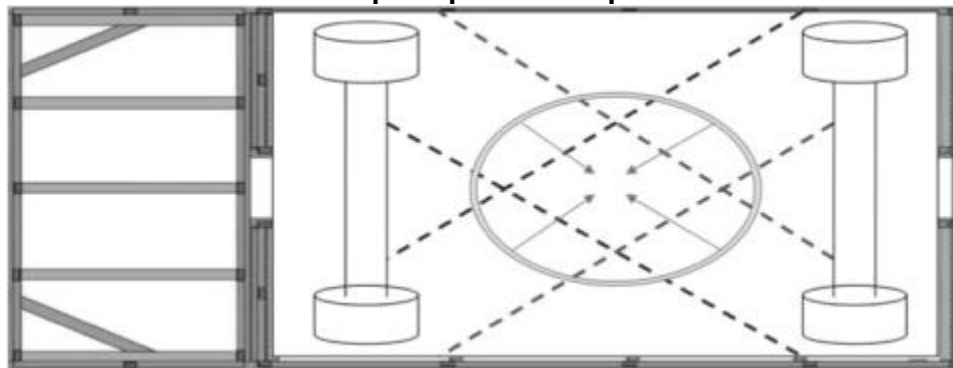
Distribución del peso para todo tipo de vehículos



Procedimientos de carga para todo tipo de vehículos

Carga correcta	Carga incorrecta
	

Amarres de carga

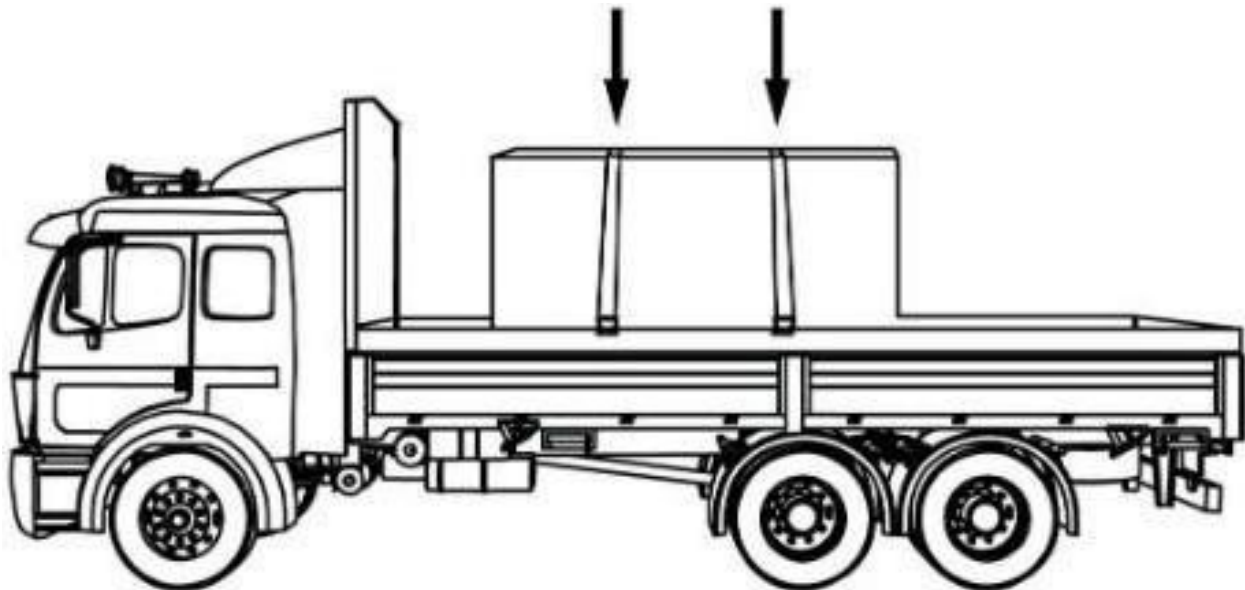

Número de amarres	Longitud de la carga	Peso de la carga
1	Menos de 1,5 metros	Menos de 500 kg
2	Menos de 1,5 metros	Más de 500 kg
2	Mayor de 1,5 metros pero menor de 3 metros	-
3	Mayor de 3 metros pero menor de 6 metros	-
4	Mayor de 6 metros pero menor de 9 metros	-
4 (como mínimo)	-	Más de 4.500
5+	Amarre adicional por cada 3 metros adicionales ganados después de 9 metros	

Límite de carga de trabajo en kilogramos (kg) por clase y tamaño de cadena					
Tamaño de la cadena (cm)	Clase 30	Clase 43	Clase 70	Clase 80	Clase 100
0,6	500	1.100	1.400	1.500	1.850
0,8	900	1.800	2.200	2.100	2.600
0,95	1.200	2.550	3.000	3.200	4.000
1,1	1.600	3.200	3.900	-	-
1,25	1.900	4.000	5.000	5.400	6.700
1,6	3.150	5.900	7.200	8.250	10.300

Configuraciones de amarre

