











Tamanhos de veículos de carga

Tipo	Eixos	Peso Bruto Máximo (Toneladas)	*Carga útil estimada (Toneladas)	Comprimento típico total da carroçaria (Metros)	Carroçaria
Camião de uma unidade	2 eixos/ 4 rodas	3,5	1	Vários	
Camião de uma unidade	2 eixos/ 6 rodas	7.5	3,5	Vários	
Camião de uma unidade	2 eixos/ 6 rodas	18,8	12	12	
Camião de uma unidade	3 eixos	26	18	12	
Camião de uma unidade	4 eixos	36	25	12	

Tamanhos de veículos de carga

Tipo	Eixos	Peso Bruto Máximo (Toneladas)	*Carga útil estimada (Toneladas)	Comprimento típico total da carroçaria (Metros)	Carroçaria
Camião de reboque trator	3 eixos	26	18	16,5	
Camião de reboque trator	4 eixos	38	24	16,5	
Camião de reboque trator	5 eixos	40	24	16,5	
Camião de reboque trator	6 eixos	41	27	16,5	
Reboque acoplado fechado	Vários	40	26	18,75	

Tamanhos de veículos de carga

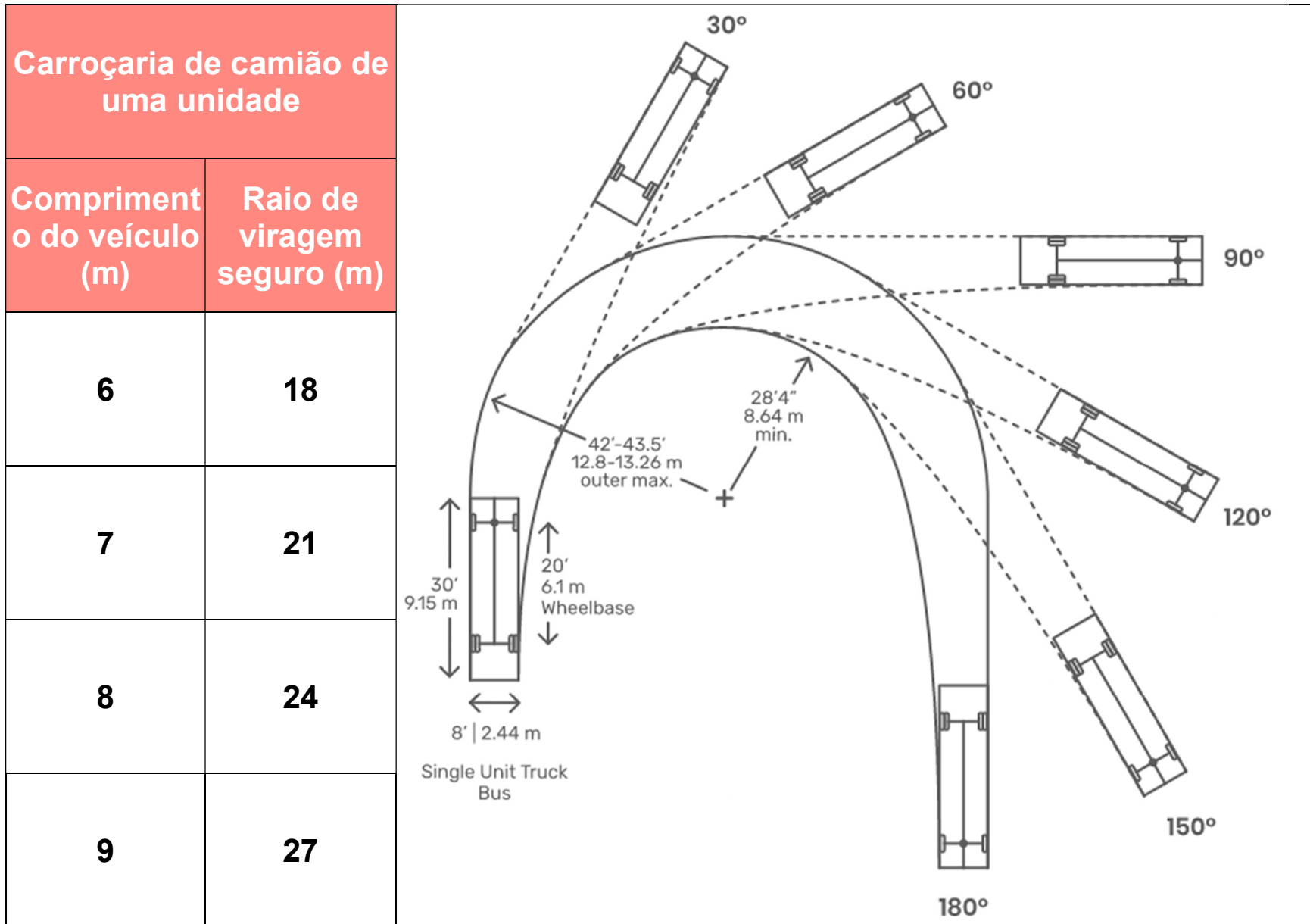

Tamanhos de veículos de carga

